



US007366564B2

(12) **United States Patent**  
**Szu et al.**

(10) **Patent No.:** **US 7,366,564 B2**  
(45) **Date of Patent:** **Apr. 29, 2008**

(54) **NONLINEAR BLIND DEMIXING OF SINGLE PIXEL UNDERLYING RADIATION SOURCES AND DIGITAL SPECTRUM LOCAL THERMOMETER**

4,723,843 A 2/1988 Zobel  
5,339,818 A 8/1994 Baker et al.  
5,383,164 A 1/1995 Sejnowski et al.  
5,539,832 A 7/1996 Weinstein et al.  
5,553,616 A \* 9/1996 Ham et al. .... 600/316

(75) Inventors: **Harold H. Szu**, Bethesda, MD (US);  
**James R. Buss**, Arlington, VA (US);  
**Ivica Kopriva**, Washington, DC (US)

(Continued)

FOREIGN PATENT DOCUMENTS

(73) Assignee: **The United States of America as represented by the Secretary of the Navy**, Washington, DC (US)

WO WO99/66638 12/1999

OTHER PUBLICATIONS

(\* ) Notice: Subject to any disclaimer, the term of this patent is extended or adjusted under 35 U.S.C. 154(b) by 707 days.

U.S. Appl. No. 60/405,327, filed Aug. 23, 2002, Harold Szu et al.

(Continued)

(21) Appl. No.: **10/652,086**

*Primary Examiner*—Eleni Mantis-Mercader  
*Assistant Examiner*—John F. Ramirez

(22) Filed: **Aug. 22, 2003**

(74) *Attorney, Agent, or Firm*—Gerhard W. Thielma, Esq.;  
Scott R. Boalick, Esq.; Matthew J. Bussan, Esq.

(65) **Prior Publication Data**  
US 2004/0181375 A1 Sep. 16, 2004

(57) **ABSTRACT**

**Related U.S. Application Data**

(60) Provisional application No. 60/405,327, filed on Aug. 23, 2002.

Changes, increase or decrease, in the body fluid flow are passively detected by using a single pixel, non-linear blind de-mixing procedure, which can be extended to general biomedical measurement and diagnoses instruments. More specifically the single pixel, non-linear blind de-mixing procedure is applied on the hot spots of rheumatic arthritis or breast cancer detection problem using passive two-color infrared imaging as well as to passively detect blockages in the body fluid circulatory system that might be of importance for coronary artery bypass surgery, diabetes and deep vein thrombosis. Other applications of the mentioned algorithm include a pair of cameras for video, a pair of antennas for cell phones, and in situ data gathering or imaging using multiple mode fiberoptical sensing as well as selective amplification hearing aids through two-ear binaural processing for de-noise echo cancellation and signal classification.

(51) **Int. Cl.**  
**A61B 6/00** (2006.01)

(52) **U.S. Cl.** ..... **600/473; 600/474**

(58) **Field of Classification Search** ..... **600/473, 600/479, 309-344, 407, 480**  
See application file for complete search history.

(56) **References Cited**

U.S. PATENT DOCUMENTS

4,718,417 A \* 1/1988 Kittrell et al. .... 606/7

**10 Claims, 30 Drawing Sheets**

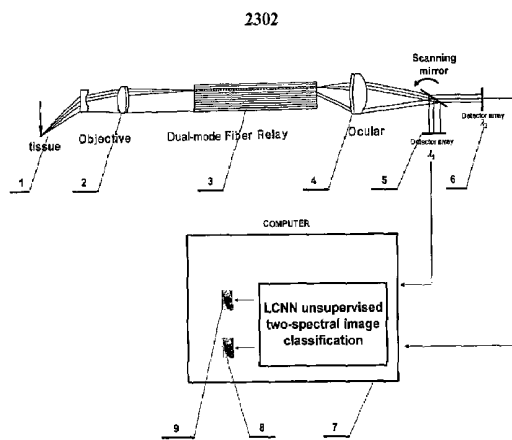
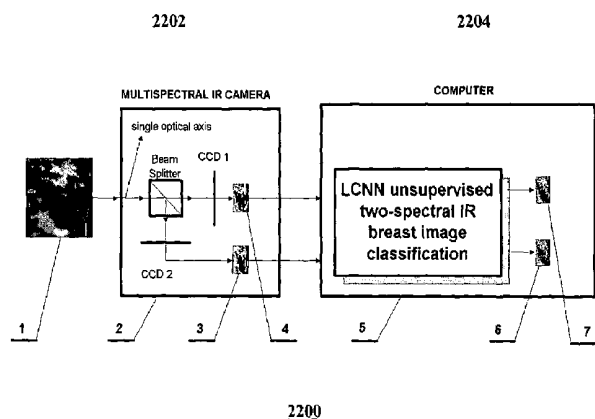

2304

2300